



# catalogue

special  
purpose  
vehicles



# HIEP HOA CATALOGUE

special purpose vehicles

## Content

- 4 **Letter from ceo**
- 5 **fire & rescue**
  - 6 • fire truck
  - 7 • Mini fire truck
  - 8 • rescue truck
  - 10 • cats
- 12 **Military and security**
  - 13 • Barbed Wire truck / Barbed wire
  - 14 • anti-riot vehicle
- 16 **environMental sector**
  - 17 • Garbage truck
  - 18 • vacuum sludge truck / sludgecarry truck / vacuum truck / Hooklift vehicle
  - 20 • aerial Platform truck /



dear valued clients and partners,

I would like to send the warmest regards to all our clients and partners around the world. I wish you a year full of success, happiness and above all healthiness.

Founded in 1996, Hiep Hoa Group, are proud to be a leading company in manufacturing, importing and research environmental equipment in Vietnam. We pride ourselves in reslessly developing and searching for advanced technology to sustain healthy environment and improve public safety and security.

Having overcome many obstacles of the transitory economy, I have witnessed an exponential growth of the group, climbing to top 500 largest enterprises in Vietnam. Hiep Hoa Group started from manufacturing simple products such as hand carts to more sophisticated vehicles such as garbage trucks, water spraying trucks, firefighting trucks, rescue trucks etc. for almost two decades, we have embraced and met challenges with our partners to make our product have their presence on every road of Vietnam, to every small corner to protect human life and property.

With clients, we always stay as a trusted company with every client and hold responsibility to our product quality.

With partners, we act as our slogan says: survive together, develop together. I see my partners as friends, see the world as a common house for us to meet, to exchange knowledge and share opportunities to promote common prosperity. In the flat world with rapid development of technology, not distance but our thinking will shape our future business. Hence, we strive to be a chain in the global value chain by our cooperative approach and we are here to make things happen.

on one hand, the objective of our company is to be competitive and profitable on the other hand, the philosophy, which is even more important to us, is our respect towards the relationship with clients and partners and our trust among each other. I hope you will continue to support us and work with us to fulfill our duty of protecting human life and our environment.

**Dao Manh Hung**

chairman and chief executive officer

FIRE &  
RESCUE

**LIGHT**

*powerful*

**CUSTOMIZATION**



**Specifications**

Model	HFF - 20	HFF - 40	HFF - 50	HFF - 60
Water tank capacity	2000l	3600l	5000l	6000l
Foam tank capacity	200l	400l	500l	600l
Body	aluminum composite			
Pump	darley, made in usa model KSP 750		darley, made in usa model KSP 1000	
substance	chemical foam and water			

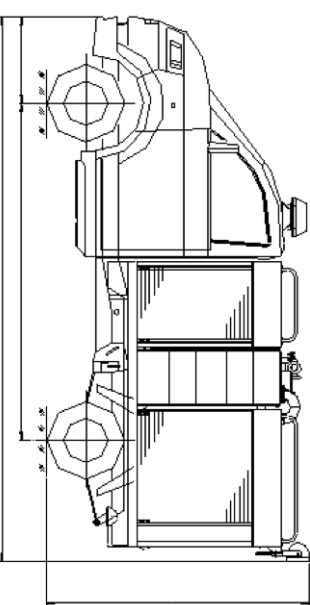
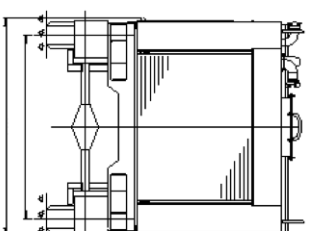
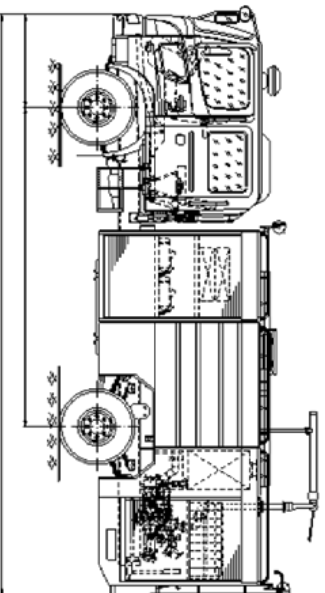
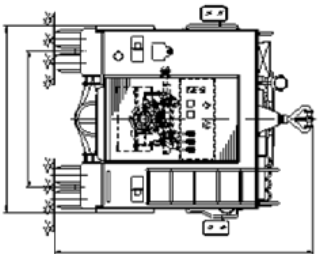

**Specifications**

Model	HFF - 20	HFF - 40	HFF - 50	HFF - 60
Length	~ 6550mm	~ 7850mm	~ 7850mm	~ 7850mm
Width	~ 2330mm	~ 2500mm	~ 2500mm	~ 2500mm
Height	~ 3250mm	~ 3250mm	~ 3250mm	~ 3250mm
Gross weight	10,400 kg	15,100 kg	15,100 kg	15,100 kg
chassis	Hino fc, isuzu frr		Hino fg, isuzu fvr	
Flow rate	3,785liter/min at 10.3bar		2,839 liter/min at 10.3 bar	
number of passengers	3 to 7			

▶ or other brands with similar specifications



# FIRE FIGHTING rescue Truck



## Specifications

Length	8.260 mm	Height	3.380 mm
Width	2.540 mm	overall length	15.100kg
chassis	Hino FG8JUS8 (euro II)	cabin	7 passengers (3 front, 4 rear)
engine	J086-UG	crane	Hydraulic crane
output	235 Ps/ 2500rpm		3 sections
Max. torque	706 n.m/1500rpm		3 ton
speed	106 km/h	Winch	front cable 14 x 50 m 5 ton

1. Working lights
2. storage
3. equipment
4. rear outrigger
5. storage



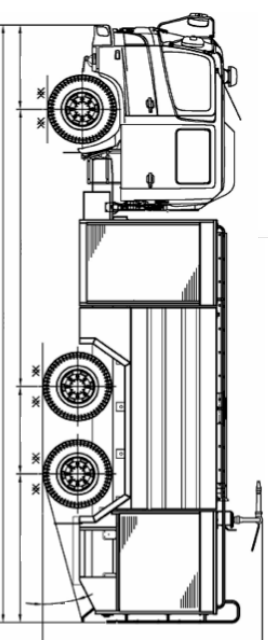
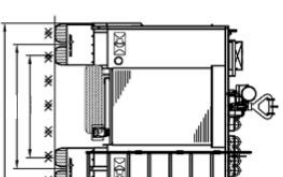

### Specifications

(customization available)  
(customization available)

type	Hcaf - 40	Hcaf - 50	Hcaf - 60	Hcaf - 80
chassis	diesel engine: Mitsubishi, Hino, Isuzu, ud etc.			
Water tank	3600l	5000l	6000l	8000l
tank - foam a	150l		200l	
tank - foam B	400l	500l	600l	800l
Pump	darley, made in usa, centrifugal single stage			

Flow rate	KSPc 750	KSPc 1000
	2,839 liters at 10.3 bar	3,785 liters at 10.3 bar

driving pump	connected with air discharger (exclusive)
air compressure	Max. output: 3,785 liter/ min

suction inlet	Quantity: 01, diameter of 100 - 125mm
discharge outlet	Quantity: 02, diameter of 65mm for water and foam, 05 cafs outlets

Light feature for one-hand operation

More effective in fire-fighting

environmentally friendly easy to use

Water saving

# MILITARY SECURITY



1. Guide roller
2. Barbed wire
3. Mechanical levers

## MILITARY AND SECURITY Barbed-Wire Handling Truck



### Specifications

Model	Hyundai Hd120	
dimensions	Length 7,670 mm	Height 3,450 mm
	Width 2,450 mm	Wheelbase 4,260 mm
Weight	Gross Weight	8,250
speed	Max. speed	123 (km/h)
Barbedwire	number of module	3
	type	Blade

## CONFIDENCE IN Riot Control

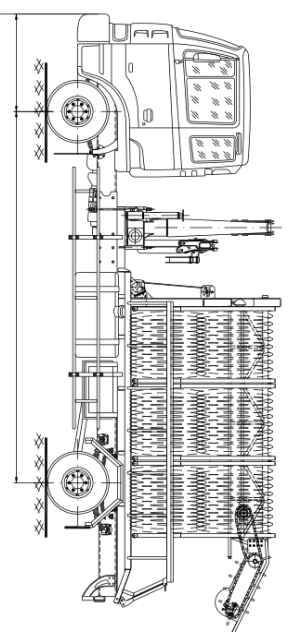



### Specifications

Model	HHB1
chassis	Hino F168lnsa
engine	4 stroke 6Cylinderdisplacement, fuel direct injection, water cooled
Weight	curb weight 12,500kg Gross weight 22,950kg
dimensions	Length x Width x Height including the front shield 8,650 x 2,480 x 3,250 mm Wheelbase 4,130 + 1,300 mm displacement 7684 cm <sup>3</sup> Max. output Iso net : 184/2500 Jis Gross : 191/2500
Fuel	type diesel tank capacity 200 liter



1. Lateral nozzle
2. Main water gun
3. control Panel
4. Bumper
5. drill





### Specifications

Model	er 06m <sup>3</sup>
chassis	3.5 ton
Garbage capacity	6m <sup>3</sup>
loading hopper	0.8m <sup>3</sup>
dimensions (length x width x height)	6,380 x 2,305 x 2,440 mm
Waste load	2,000 kg
tank dimension (length x width x height)	3,200 x 2,000 x 1,450 mm
front tyre	7.00-16/14Pr
rear tyre	7.00-16/14Pr

specifications can be changed without prior notice customization option available

er 8.5m <sup>3</sup>	er 9.5m <sup>3</sup>	er 14.5m <sup>3</sup>	er 20m <sup>3</sup>
5.5 ton	6.2 ton	9.4 ton	15 ton
8.5m <sup>3</sup>	9.5m <sup>3</sup>	14.5m <sup>3</sup>	20m <sup>3</sup>
1m <sup>3</sup>	1.2m <sup>3</sup>	1.5m <sup>3</sup>	2m <sup>3</sup>
7,330 x 2,140 x 2,700 mm	6,610 x 2,175 x 2,740 mm	7,520 x 2,145 x 2,635 mm	9,580 x 2,470 x 3,450 mm
3,500 kg	4,500 kg	6,500 kg	11,000 kg
4,050 x 2,000 x 1,450 mm	3,485 x 2,037 x 1,674 mm	4,100 x 2,200 x 1,810 mm	5,430 x 2,278 x 2,040 mm
8.25 - 16 - 14Pr	8.25 - 16 - 14Pr	10.00 - 20 - 16Pr	10.00 - 20 - 16Pr
8.25 - 16 - 14Pr	8.25 - 16 - 14Pr	10.00 - 20 - 16Pr	10.00 - 20 - 16Pr

## Sludge Vacuum Truck

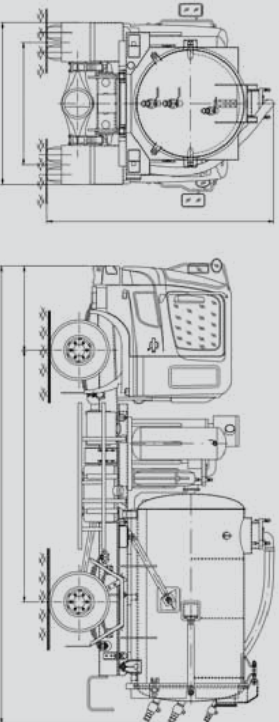

### Specifications

Model	HP 3m <sup>3</sup>	HP 4m <sup>3</sup>	HP 5m <sup>3</sup>
chassis	3.5 ton	5.5 ton	6.2 ton
tank capacity	3m <sup>3</sup>	4m <sup>3</sup>	5m <sup>3</sup>
dimensions (length x width x height)	5,500 x 2,000 x 2,420 mm	6,300 x 2,150 x 2,750 mm	6,200 x 2,175 x 2720 mm
Weight	3,000 kg	4,000 kg	5,200 kg
tank dimension (length x width x height)	2,500 x 1,000 x 1,000 mm	3,010 x 1,440 x 1,440 mm	2,600 x 1,150 x 1,150 mm
Front tyre	7.00-16/14Pr	8.25 - 16/14 Pr	8.25 - 16/14 Pr
rear tyre	7.00-16/14Pr	8.25 - 16/14 Pr	8.25 - 16/14 Pr

## Vacuum Truck



### Sludge Carry Truck

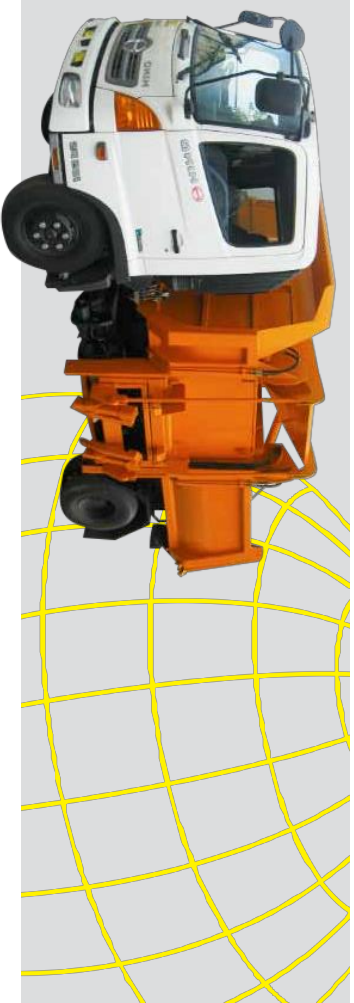

### Hooklift Vehicle



## Aerial Platform Truck



Overall dimensions (length x width x height)	9,670x2,500x3,730 mm
Payload	4,350 kg
Gross weight	15,100 kg
Body dimensions (length x width x height)	6,400 x 2,360 x 450 mm
Body wall	steel, thickness of 2mm
Body floor	Wooden, thickness of 3mm
crane system with case	<b>Lifting capacity: 6,600kg at 2.5m</b>

Max. working radius	18.7 m
Max. lifting height	21.7 m
Lifting angle	1°-76°
turning angle	360° constantly
Winch	Φ 10" 100 m
case	composite
Material	200 kg (2 persons and tools)
Max. lifting capacity	Hydraulic balance system
safety equipment	

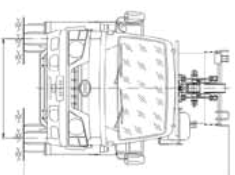
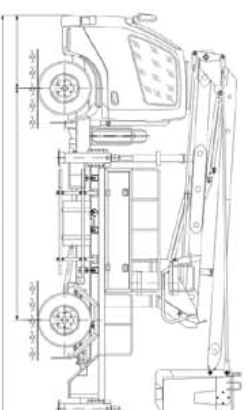

## Specifications

Overall dimensions (length x width x height)	5,620 x 1,950 x 2,930 mm
Wheelbase	3,380 mm
Payload	2,500 kg
Gross weight	7,500kg
Lifting system	Lifting location
number of sections	2 points - on the cage and under the control panel
turning angle	02 sections
Lifting angle	360° towards 2 directions
Max. lifting height	from 0° - 60°
from the ground	10 m
Max. working radius	4 m
cage capacity	200 kg - 2 working persons
safety system	emergency stop, auxiliary pump, belt, ...

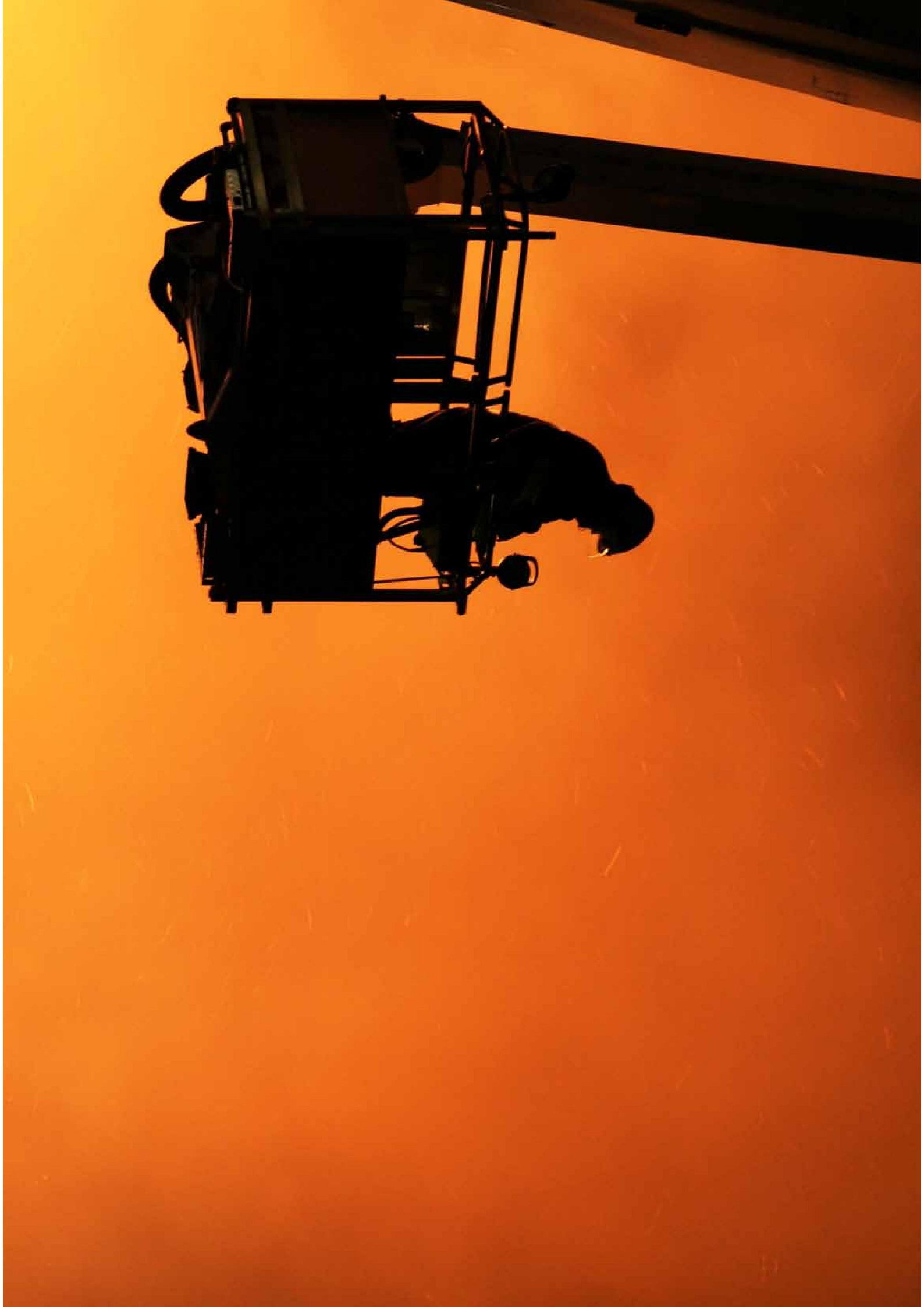



**HIEPHOA GROUP**

No. 3/107 Nguyen Chi Thanh - Hanoi

Mr. David Nhat Anh: +84 988 452 429

Ms. Hang: +84 932 311 699

Factory: KM 30, QL 5, Minh Duc, My Hao district, Hung Yen Province, Viet Nam

Phone: +84 24 3773 9913

Fax: +84 24 3773 1962

Email: [marketing@hiephoa.com.vn](mailto:marketing@hiephoa.com.vn)

[www.hiephoa.com.vn](http://www.hiephoa.com.vn)